

APPENDIX D

SOME USEFUL NETWORK THEOREMS

Introduction

In this appendix we review three network theorems that are useful in simplifying the analysis of electronic circuits: Thévenin's theorem, Norton's theorem, and the source-absorption theorem.

D.1 Thévenin's Theorem

Thévenin's theorem is used to represent a part of a network by a voltage source V_t and a series impedance Z_t , as shown in Fig. D.1. Figure D.1(a) shows a network divided into two parts, A and B. In Fig. D.1(b), part A of the network has been replaced by its Thévenin equivalent: a voltage source V_t and a series impedance Z_t . Figure D.1(c) illustrates how V_t is to be determined: Simply open-circuit the two terminals of network A and measure (or calculate) the voltage that appears between these two terminals. To determine Z_t , we reduce all external (i.e., independent) sources in network A to zero by short-circuiting voltage sources and open-circuiting current sources. The impedance Z_t will be equal to the input impedance of network A after this reduction has been performed, as illustrated in Fig. D.1(d).

D.2 Norton's Theorem

Norton's theorem is the *dual* of Thévenin's theorem. It is used to represent a part of a network by a current source I_n and a parallel impedance Z_n , as shown in Fig. D.2. Figure D.2(a) shows a network divided into two parts, A and B. In Fig. D.2(b), part A has been replaced by its Norton's equivalent: a current source I_n and a parallel impedance Z_n . The Norton's current source I_n can be measured (or calculated) as shown in Fig. D.2(c). The terminals of the network being reduced (network A) are shorted, and the current I_n will be equal simply to the short-circuit current. To determine the impedance Z_n , we first reduce the external excitation in network A to zero: That is, we short-circuit independent voltage sources and open-circuit independent current sources. The impedance Z_n will be equal to the input impedance of network A after this source-elimination process has taken place. Thus the Norton impedance Z_n is equal to the Thévenin impedance Z_t . Finally, note that $I_n = V_t/Z$, where $Z = Z_n = Z_t$.

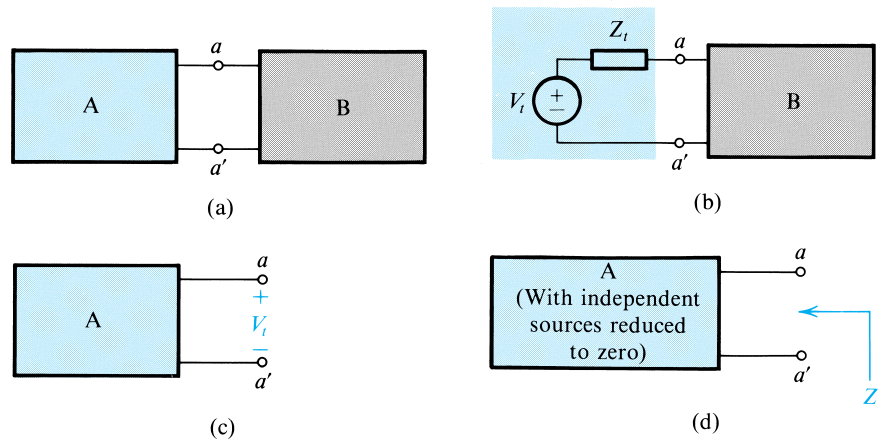

Figure D.1 Thévenin's theorem.

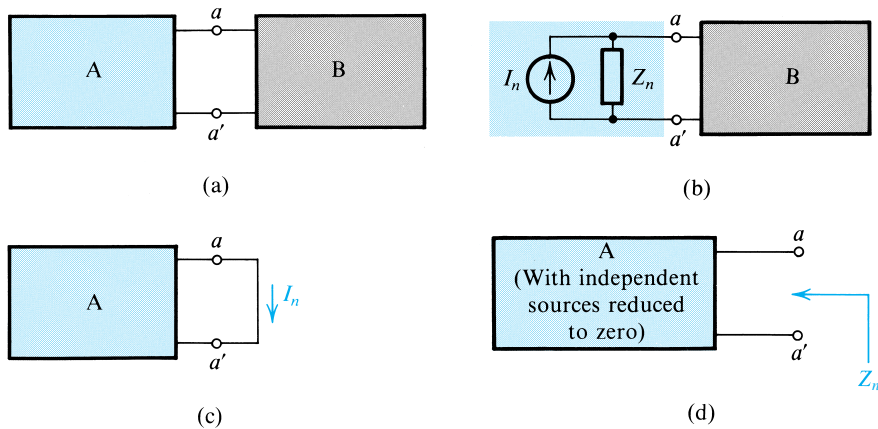

Figure D.2 Norton's theorem.

Example D.1

Figure D.3(a) shows a bipolar junction transistor circuit. The transistor is a three-terminal device with the terminals labeled E (emitter), B (base), and C (collector). As shown, the base is connected to the dc power supply V^+ via the voltage divider composed of R_1 and R_2 . The collector is connected to the dc supply V^+ through R_3 and to ground through R_4 . To simplify the analysis, we wish to apply Thévenin's theorem to reduce the circuit.

Solution

Thévenin's theorem can be used at the base side to reduce the network composed of V^+ , R_1 , and R_2 to a dc voltage source V_{BB} ,

$$V_{BB} = V^+ \frac{R_2}{R_1 + R_2}$$

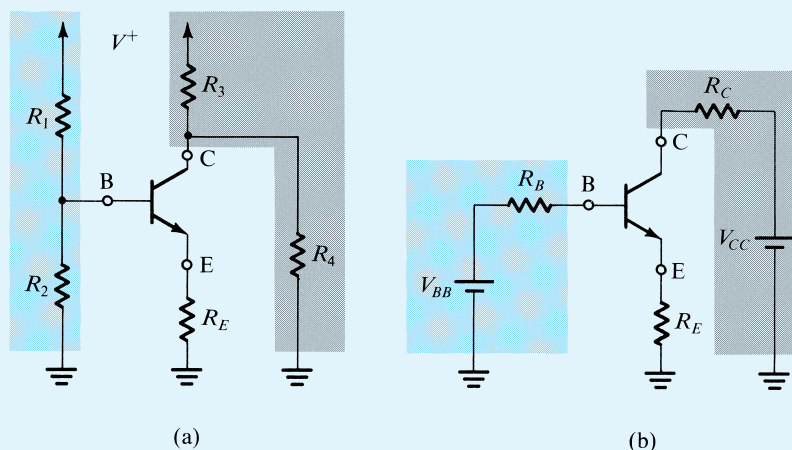

Figure D.3 Thévenin's theorem applied to simplify the circuit of (a) to that in (b). (See Example D.1.)

and a resistance R_B ,

$$R_B = R_1 \parallel R_2$$

where \parallel denotes “in parallel with.” At the collector side, Thévenin's theorem can be applied to reduce the network composed of V^+ , R_3 , and R_4 to a dc voltage source V_{CC} ,

$$V_{CC} = V^+ \frac{R_4}{R_3 + R_4}$$

and a resistance R_C ,

$$R_C = R_3 \parallel R_4$$

The reduced circuit is shown in Fig. D.3(b).

D.3 Source-Absorption Theorem

Consider the situation shown in Fig. D.4. In the course of analyzing a network, we find a controlled current source I_x appearing between two nodes whose voltage difference is the controlling voltage V_x . That is, $I_x = g_m V_x$ where g_m is a conductance. We can replace this controlled source by an impedance $Z_x = V_x / I_x = 1/g_m$, as shown in Fig. D.4, because the current drawn by this impedance will be equal to the current of the controlled source that we have replaced.

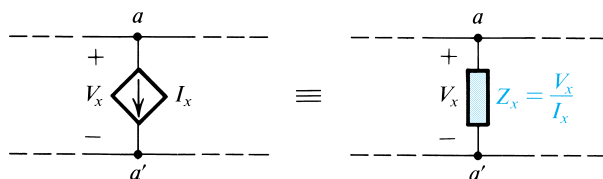

Figure D.4 The source-absorption theorem.

Example D.2

Figure D.5(a) shows the small-signal, equivalent-circuit model of a transistor. We want to find the resistance R_{in} “looking into” the emitter terminal E—that is, the resistance between the emitter and ground—with the base B and collector C grounded.

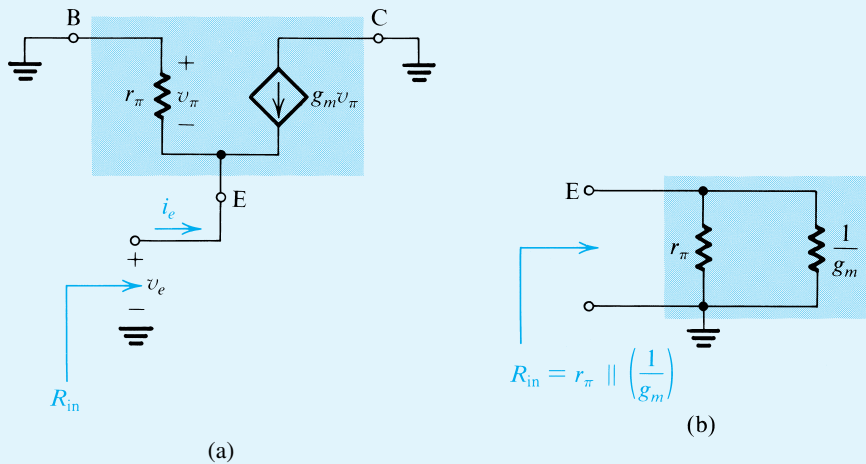

Figure D.5 Circuit for Example D.2.

Solution

From Fig. D.5(a), we see that the voltage v_{π} will be equal to $-v_e$. Thus, looking between E and ground, we see a resistance r_{π} in parallel with a current source drawing a current $g_m v_e$ away from terminal E. The latter source can be replaced by a resistance $(1/g_m)$, resulting in the input resistance R_{in} given by

$$R_{in} = r_{\pi} \parallel (1/g_m)$$

as illustrated in Fig. D.5(b).

EXERCISES

- D.1** A source is measured and found to have a 10-V open-circuit voltage and to provide 1 mA into a short circuit. Calculate its Thévenin and Norton equivalent source parameters.
Ans. $V_t = 10 \text{ V}$; $Z_t = Z_n = 10 \text{ k}\Omega$; $I_n = 1 \text{ mA}$
- D.2** In the circuit shown in Fig. ED.2, the diode has a voltage drop $V_D \simeq 0.7 \text{ V}$. Use Thévenin’s theorem to simplify the circuit and hence calculate the diode current I_D .
Ans. 1 mA

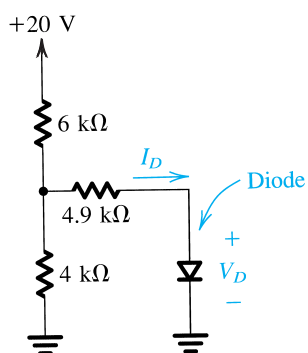

Figure ED.2

- D.3** The two-terminal device M in the circuit of Fig. ED.3 has a current $I_M \simeq 1$ mA independent of the voltage V_M across it. Use Norton's theorem to simplify the circuit and hence calculate the voltage V_M .

Ans. 5 V

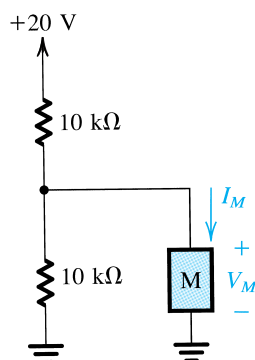

Figure ED.3

PROBLEMS

D.1 Consider the Thévenin equivalent circuit characterized by V_t and Z_t . Find the open-circuit voltage V_{oc} and the short-circuit current I_{sc} (i.e., the current that flows when the terminals are shorted together). Express Z_t in terms of V_{oc} and I_{sc} .

D.2 Repeat Problem D.1 for a Norton equivalent circuit characterized by I_n and Z_n .

D.3 A voltage divider consists of a 9-k Ω resistor connected to +10 V and a resistor of 1 k Ω connected to ground. What is the Thévenin equivalent of this voltage divider? What output voltage results if it is loaded with 1 k Ω ? Calculate this two ways: directly and using your Thévenin equivalent.

D-6 Appendix D Some Useful Network Theorems

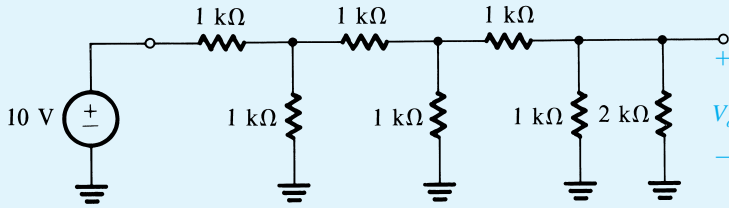

Figure PD.4

D.4 Find the output voltage and output resistance of the circuit shown in Fig. PD.4 by considering a succession of Thévenin equivalent circuits.

D.5 Repeat Example D.2 with a resistance R_B connected between B and ground in Fig. D.5 (i.e., rather than directly grounding the base B as indicated in Fig. D.5).

D.6 Figure PD.6(a) shows the circuit symbol of a device known as the p -channel junction field-effect transistor (JFET). As indicated, the JFET has three terminals. When the gate terminal G is connected to the source terminal S, the two-terminal device shown in Fig. PD.6(b) is obtained. Its $i-v$ characteristic is given by

$$i = I_{DSS} \left[2 \frac{v}{V_p} - \left(\frac{v}{V_p} \right)^2 \right] \quad \text{for } v \leq V_p$$

$$i = I_{DSS} \quad \text{for } v \geq V_p$$

where I_{DSS} and V_p are positive constants for the particular JFET. Now consider the circuit shown in Fig. PD.6(c) and let $V_p = 2$ V and $I_{DSS} = 2$ mA. For $V^+ = 10$ V show that the JFET is operating in the constant-current mode and find the voltage across it. What is the minimum value of V^+ for which this mode of operation is maintained? For $V^+ = 2$ V find the values of I and V .

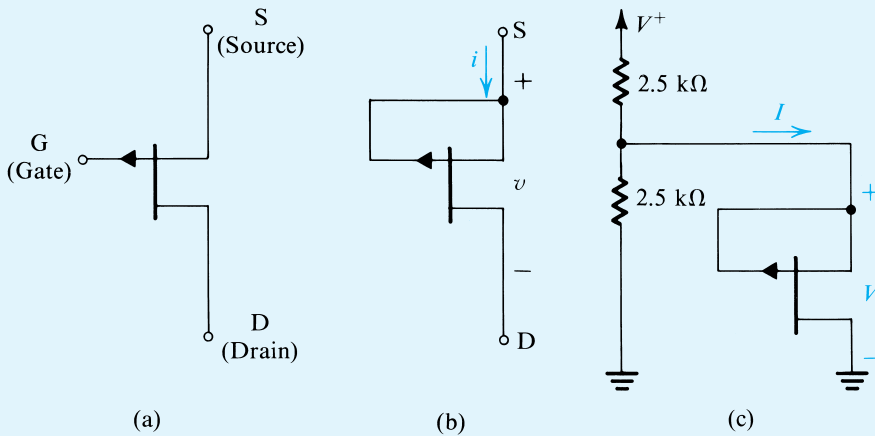

Figure PD.6