

APPENDIX E

SINGLE-TIME-CONSTANT CIRCUITS

Introduction

Single-time-constant (STC) circuits are those circuits that are composed of or can be reduced to one reactive component (inductance or capacitance) and one resistance. An STC circuit formed of an inductance L and a resistance R has a time constant $\tau = L/R$. The time constant τ of an STC circuit composed of a capacitance C and a resistance R is given by $\tau = CR$.

Although STC circuits are quite simple, they play an important role in the design and analysis of linear and digital circuits. For instance, the analysis of an amplifier circuit can usually be reduced to the analysis of one or more STC circuits. For this reason, we will review in this appendix the process of evaluating the response of STC circuits to sinusoidal and other input signals such as step and pulse waveforms. The latter signal waveforms are encountered in some amplifier applications but are more important in switching circuits, including digital circuits.

E.1 Evaluating the Time Constant

The first step in the analysis of an STC circuit is to evaluate its time constant τ .

Example E.1

Reduce the circuit in Fig. E.1(a) to an STC circuit, and find its time constant.

Solution

The reduction process is illustrated in Fig. E.1 and consists of repeated applications of Thévenin's theorem. From the final circuit (Fig. E.1c), we obtain the time constant as

$$\tau = C\{R_4 \parallel [R_3 + (R_1 \parallel R_2)]\}$$

E.1.1 Rapid Evaluation of τ

In many instances, it will be important to be able to evaluate rapidly the time constant τ of a given STC circuit. A simple method for accomplishing this goal consists first of reducing the excitation to zero; that is, if the excitation is by a voltage source, short it, and if by a current

E-2 Appendix E Single-Time-Constant Circuits

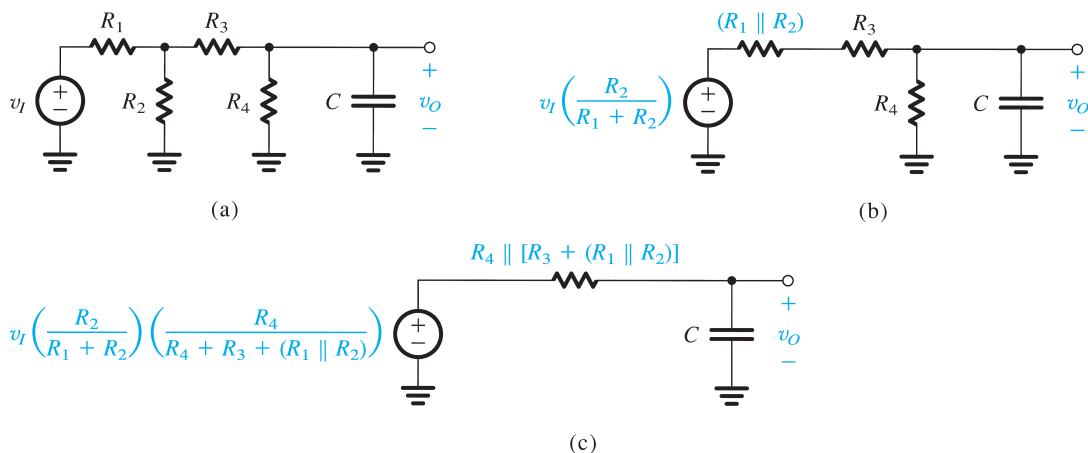

Figure E.1 The reduction of the circuit in (a) to the STC circuit in (c) through the repeated application of Thévenin’s theorem.

source, open it. Then, if the circuit has one reactive component and a number of resistances, “grab hold” of the two terminals of the reactive component (capacitance or inductance) and find the equivalent resistance R_{eq} seen by the component. The time constant is then either L/R_{eq} or CR_{eq} . As an example, in the circuit of Fig. E.1(a), we find that the capacitor C “sees” a resistance R_4 in parallel with the series combination of R_3 and R_2 in parallel with R_1 . Thus

$$R_{eq} = R_4 \parallel [R_3 + (R_2 \parallel R_1)]$$

and the time constant is CR_{eq} .

In some cases it may be found that the circuit has one resistance and a number of capacitances or inductances. In such a case, the procedure should be inverted; that is, “grab hold” of the resistance terminals and find the equivalent capacitance C_{eq} , or equivalent inductance L_{eq} , seen by this resistance. The time constant is then found as $C_{eq}R$ or L_{eq}/R . This is illustrated in Example E.2.

Example E.2

Find the time constant of the circuit in Fig. E.2.

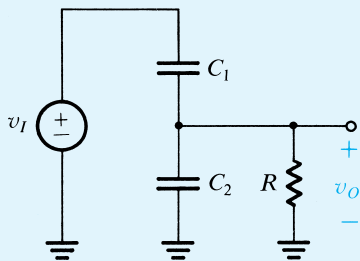

Figure E.2 Circuit for Example E.2.

Solution

After reducing the excitation to zero by short-circuiting the voltage source, we see that the resistance R “sees” an equivalent capacitance $C_1 + C_2$. Thus, the time constant τ is given by

$$\tau = (C_1 + C_2)R$$

Finally, in some cases an STC circuit has more than one resistance and more than one capacitance (or more than one inductance). Such cases require some initial work to simplify the circuit, as illustrated by Example E.3.

Example E.3

Here we show that the response of the circuit in Fig. E.3(a) can be obtained using the method of analysis of STC circuits.

Solution

The analysis steps are illustrated in Fig. E.3. In Fig. E.3(b) we show the circuit excited by two separate but equal voltage sources. The reader should convince himself or herself of the equivalence of the circuits in Fig. E.3(a) and E.3(b). The “trick” employed to obtain the arrangement in Fig. E.3(b) is a very useful one.

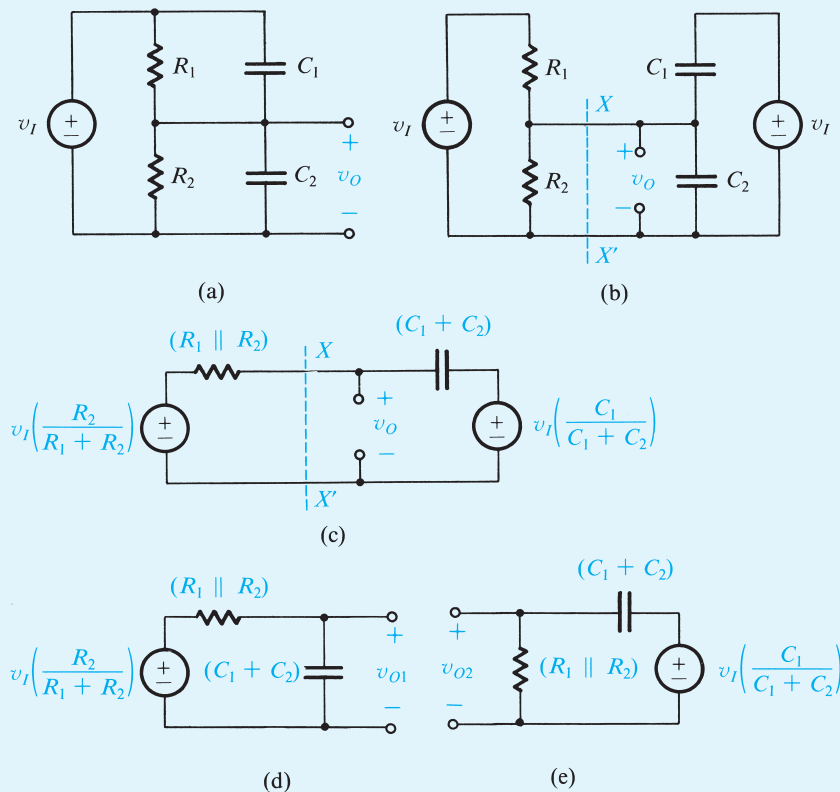

Figure E.3 The response of the circuit in (a) can be found by superposition, that is, by summing the responses of the circuits in (d) and (e).

Example E.3 *continued*

Application of Thévenin's theorem to the circuit to the left of the line XX' and then to the circuit to the right of that line results in the circuit of Fig. E.3(c). Since this is a linear circuit, the response may be obtained using the principle of superposition. Specifically, the output voltage v_o will be the sum of the two components v_{o1} and v_{o2} . The first component, v_{o1} , is the output due to the left-hand-side voltage source with the other voltage source reduced to zero. The circuit for calculating v_{o1} is shown in Fig. E.3(d). It is an STC circuit with a time constant given by

$$\tau = (C_1 + C_2)(R_1 \parallel R_2)$$

Similarly, the second component v_{o2} is the output obtained with the left-hand-side voltage source reduced to zero. It can be calculated from the circuit of Fig. E.3(e), which is an STC circuit with the same time constant τ .

Finally, it should be observed that the fact that the circuit is an STC one can also be ascertained by setting the independent source v_i in Fig. E.3(a) to zero. Also, the time constant is then immediately obvious.

E.2 Classification of STC Circuits

STC circuits can be classified into two categories, *low-pass* (LP) and *high-pass* (HP) types, with each category displaying distinctly different signal responses. The task of finding whether an STC circuit is of LP or HP type may be accomplished in a number of ways, the simplest of which uses the frequency domain response. Specifically, low-pass circuits pass dc (i.e., signals with zero frequency) and attenuate high frequencies, with the transmission being zero at $\omega = \infty$. Thus, we can test for the circuit type either at $\omega = 0$ or at $\omega = \infty$. At $\omega = 0$ capacitors should be replaced by open circuits ($1/j\omega C = \infty$) and inductors should be replaced by short circuits ($j\omega L = 0$). Then if the output is zero, the circuit is of the high-pass type, while if the output is finite, the circuit is of the low-pass type. Alternatively, we may test at $\omega = \infty$ by replacing capacitors with short circuits ($1/j\omega C = 0$) and inductors with open circuits ($j\omega L = \infty$). Then if the output is finite, the circuit is of the HP type, whereas if the output is zero, the circuit is of the LP type. In Table E.1, which provides a summary of these results, s.c. stands for short circuit and o.c. for open circuit.

Figure E.4 shows examples of low-pass STC circuits, and Fig. E.5 shows examples of high-pass STC circuits. For each circuit we have indicated the input and output variables of interest. Note that a given circuit can be of either category, depending on the input and output variables. The reader is urged to verify, using the rules of Table E.1, that the circuits of Figs. E.4 and E.5 are correctly classified.

Table E.1 Rules for finding the type of STC Circuit

Test at	Replace	Circuit is LP if	Circuit is HP if
$\omega = 0$	C by o.c. L by s.c.	output is finite	output is zero
$\omega = \infty$	C by s.c. L by o.c.	output is zero	output is finite

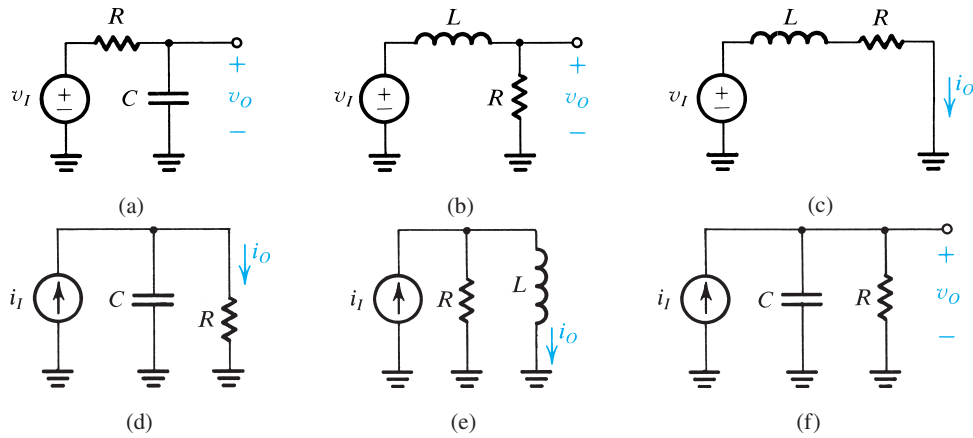

Figure E.4 STC circuits of the low-pass type.

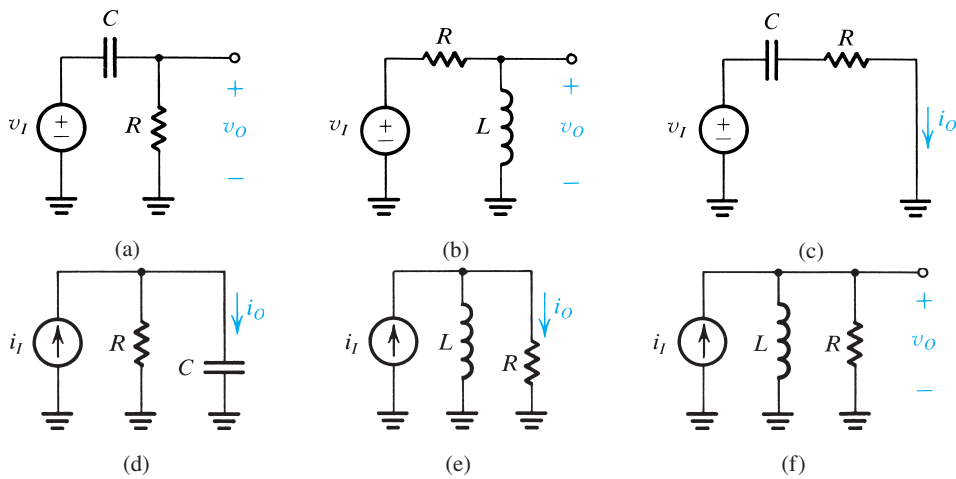

Figure E.5 STC circuits of the high-pass type.

EXERCISES

E.1 Find the time constants for the circuits shown in Fig. EE.1.

Ans. (a) $\frac{(L_1 \parallel L_2)}{R}$; (b) $\frac{(L_1 \parallel L_2)}{(R_1 \parallel R_2)}$

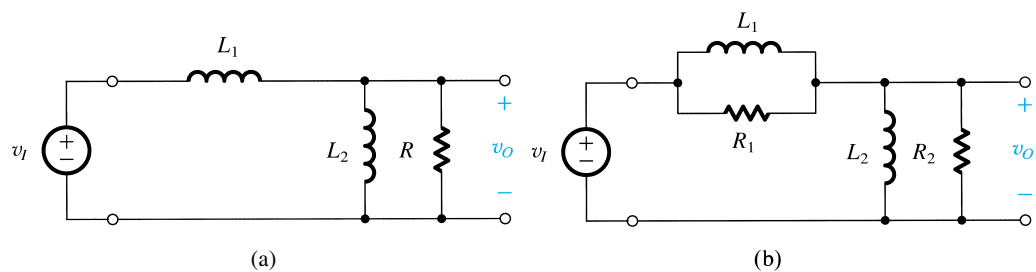

Figure EE.1

E.2 Classify the following circuits as STC high-pass or low-pass: Fig. E.4(a) with output i_o in C to ground; Fig. E.4(b) with output i_o in R to ground; Fig. E.4(d) with output i_o in C to ground; Fig. E.4(e) with output i_o in R to ground; Fig. E.5(b) with output i_o in L to ground; and Fig. E.5(d) with output v_o across C .

Ans. HP; LP; HP; HP; LP; LP

E.3 Frequency Response of STC Circuits

E.3.1 Low-Pass Circuits

The transfer function $T(s)$ of an STC low-pass circuit can always be written in the form

$$T(s) = \frac{K}{1 + (s/\omega_0)} \quad (\text{E.1})$$

which, for physical frequencies, where $s = j\omega$, becomes

$$T(j\omega) = \frac{K}{1 + j(\omega/\omega_0)} \quad (\text{E.2})$$

where K is the magnitude of the transfer function at $\omega = 0$ (dc) and ω_0 is defined by

$$\omega_0 = 1/\tau$$

with τ being the time constant. Thus the magnitude response is given by

$$|T(j\omega)| = \frac{K}{\sqrt{1 + (\omega/\omega_0)^2}} \quad (\text{E.3})$$

and the phase response is given by

$$\phi(\omega) = -\tan^{-1}(\omega/\omega_0) \quad (\text{E.4})$$

Figure E.6 sketches the magnitude and phase responses for an STC low-pass circuit. The magnitude response shown in Fig. E.6(a) is simply a graph of the function in Eq. (E.3). The magnitude is normalized with respect to the dc gain K and is expressed in decibels; that is, the plot is for $20 \log|T(j\omega)/K|$, with a logarithmic scale used for the frequency axis. Furthermore, the frequency variable has been normalized with respect to ω_0 . As shown, the magnitude curve is closely defined by two straight-line asymptotes. The low-frequency asymptote is a horizontal straight line at 0 dB. To find the slope of the high-frequency asymptote, consider Eq. (E.3) and let $\omega/\omega_0 \gg 1$, resulting in

$$|T(j\omega)| \simeq K \frac{\omega_0}{\omega}$$

It follows that if ω doubles in value, the magnitude is halved. On a logarithmic frequency axis, doublings of ω represent equally spaced points, with each interval called an *octave*. Halving the magnitude function corresponds to a 6-dB reduction in transmission ($20 \log 0.5 = -6$ dB). Thus the slope of the high-frequency asymptote is -6 dB/octave. This can be equivalently expressed as -20 dB/decade, where “decade” indicates an increase in frequency by a factor of 10.

The two straight-line asymptotes of the magnitude–response curve meet at the “corner frequency” or “break frequency” ω_0 . The difference between the actual magnitude–response

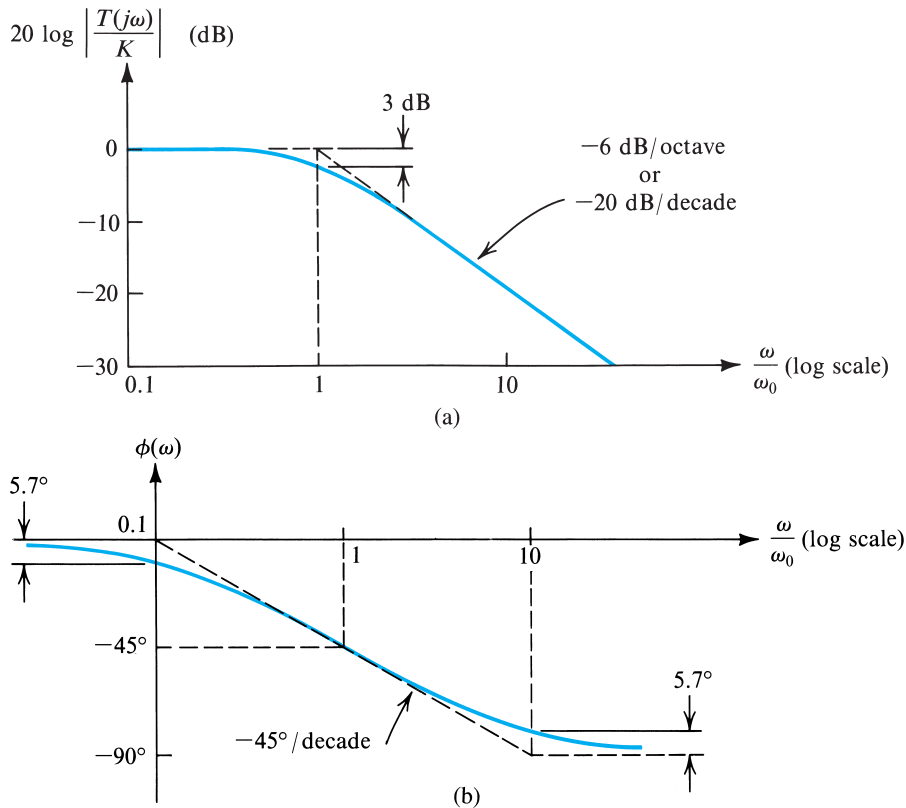

Figure E.6 (a) Magnitude and (b) phase response of STC circuits of the low-pass type.

curve and the asymptotic response is largest at the corner frequency, where its value is 3 dB. To verify that this value is correct, simply substitute $\omega = \omega_0$ in Eq. (E.3) to obtain

$$|T(j\omega_0)| = K/\sqrt{2}$$

Thus at $\omega = \omega_0$, the gain drops by a factor of $\sqrt{2}$ relative to the dc gain, which corresponds to a 3-dB reduction in gain. The corner frequency ω_0 is appropriately referred to as the 3-dB frequency.

Similar to the magnitude response, the phase-response curve, shown in Fig. E.6(b), is closely defined by straight-line asymptotes. Note that at the corner frequency the phase is -45° , and that for $\omega \gg \omega_0$ the phase approaches -90° . Also note that the $-45^\circ/\text{decade}$ straight line approximates the phase function, with a maximum error of 5.7° , over the frequency range $0.1\omega_0$ to $10\omega_0$.

Example E.4

Consider the circuit shown in Fig. E.7(a), where an ideal voltage amplifier of gain $\mu = -100$ has a small (10-pF) capacitance connected in its feedback path. The amplifier is fed by a voltage source having a source resistance of 100 k Ω . Show that the frequency response V_o/V_s of this amplifier is equivalent to that of an STC circuit, and sketch the magnitude response.

Example E.4 continued

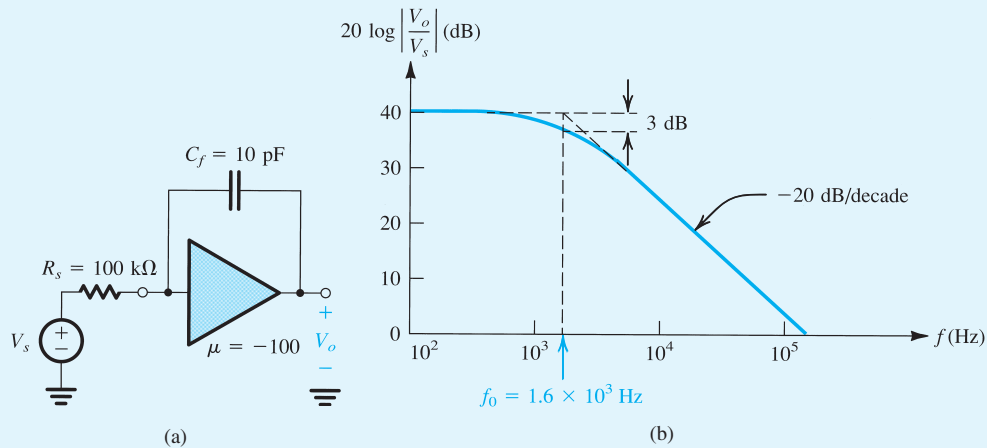

Figure E.7 (a) An amplifier circuit and (b) a sketch of the magnitude of its transfer function.

Solution

Direct analysis of the circuit in Fig. E.7(a) results in the transfer function

$$\frac{V_o}{V_s} = \frac{\mu}{1 + sRC_f(-\mu + 1)}$$

which can be seen to be that of a low-pass STC circuit with a dc gain $\mu = -100$ (or, equivalently, 40 dB) and a time constant $\tau = RC_f(-\mu + 1) = 100 \times 10^3 \times 10 \times 10^{-12} \times 101 \simeq 10^{-4} \text{ s}$, which corresponds to a frequency $\omega_0 = 1/\tau = 10^4 \text{ rad/s}$. The magnitude response is sketched in Fig. E.7(b).

E.3.2 High-Pass Circuits

The transfer function $T(s)$ of an STC high-pass circuit can always be expressed in the form

$$T(s) = \frac{Ks}{s + \omega_0} \tag{E.5}$$

which for physical frequencies $s = j\omega$ becomes

$$T(j\omega) = \frac{K}{1 - j\omega_0/\omega} \tag{E.6}$$

where K denotes the gain as s or ω approaches infinity and ω_0 is the inverse of the time constant τ ,

$$\omega_0 = 1/\tau$$

The magnitude response

$$|T(j\omega)| = \frac{K}{\sqrt{1 + (\omega_0/\omega)^2}} \tag{E.7}$$

and the phase response

$$\phi(\omega) = \tan^{-1}(\omega_0/\omega) \tag{E.8}$$

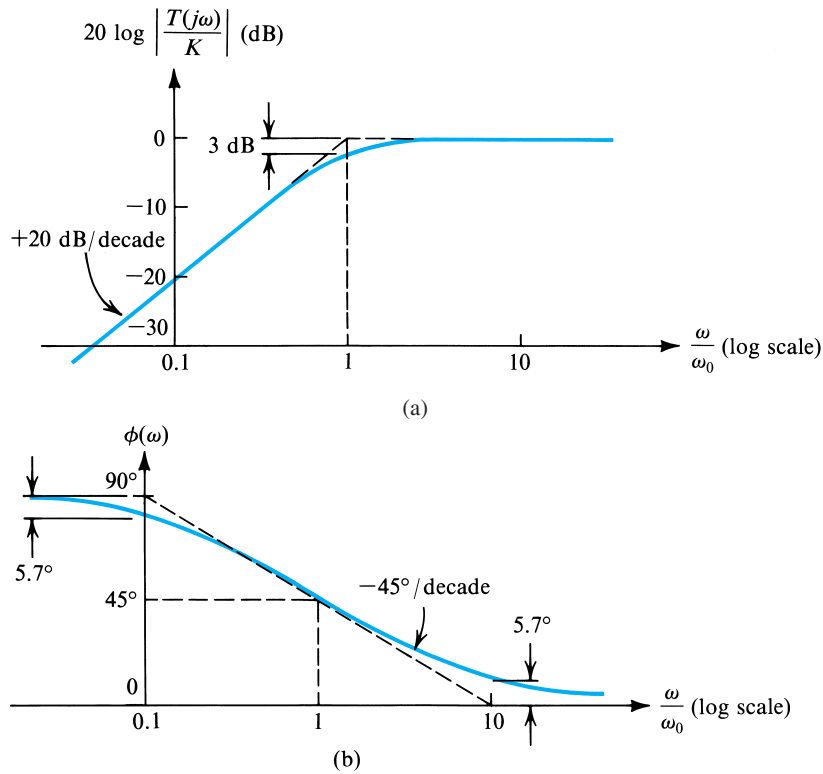

Figure E.8 (a) Magnitude and (b) phase response of STC circuits of the high-pass type.

are sketched in Fig. E.8. As in the low-pass case, the magnitude and phase curves are well defined by straight-line asymptotes. Because of the similarity (or, more appropriately, duality) with the low-pass case, no further explanation will be given.

EXERCISES

- E.3** Find the dc transmission, the corner frequency f_0 , and the transmission at $f = 2$ MHz for the low-pass STC circuit shown in Fig. EE.3.

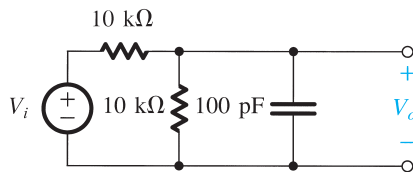

Figure EE.3

- Ans.** -6 dB; 318 kHz; -22 dB
- E.4** Find the transfer function $T(s)$ of the circuit in Fig. E.2. What type of STC network is it?

Ans. $T(s) = \frac{C_1}{C_1 + C_2} \frac{s}{s + [1/(C_1 + C_2)R]}$; HP

E.5 For the situation discussed in Exercise E.4, if $R = 10 \text{ k}\Omega$, find the capacitor values that result in the circuit having a high-frequency transmission of 0.5 V/V and a corner frequency $\omega_0 = 10 \text{ rad/s}$.

Ans. $C_1 = C_2 = 5 \mu\text{F}$

E.6 Find the high-frequency gain, the 3-dB frequency f_0 , and the gain at $f = 1 \text{ Hz}$ of the capacitively coupled amplifier shown in Fig. EE.6. Assume the voltage amplifier to be ideal.

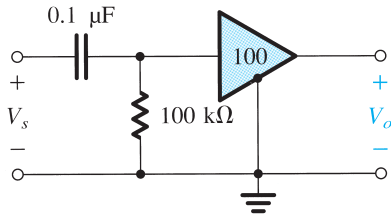

Figure EE.6

Ans. 40 dB; 15.9 Hz; 16 dB

E.4 Step Response of STC Circuits

In this section we consider the response of STC circuits to the step-function signal shown in Fig. E.9. Knowledge of the step response enables rapid evaluation of the response to other switching-signal waveforms, such as pulses and square waves.

E.4.1 Low-Pass Circuits

In response to an input step signal of height S , a low-pass STC circuit (with a dc gain $K = 1$) produces the waveform shown in Fig. E.10. Note that while the input rises from 0 to S at $t = 0$, the output does not respond immediately to this transient and simply begins to rise exponentially toward the *final* dc value of the input, S . In the long term—that is, for $t \gg \tau$ —the output approaches the dc value S , a manifestation of the fact that low-pass circuits faithfully pass dc.

The equation of the output waveform can be obtained from the expression

$$y(t) = Y_\infty - (Y_\infty - Y_{0+})e^{-t/\tau} \quad (\text{E.9})$$

where Y_∞ denotes the *final* value or the value toward which the output is heading and Y_{0+} denotes the value of the output immediately after $t = 0$. This equation states that *the output at*

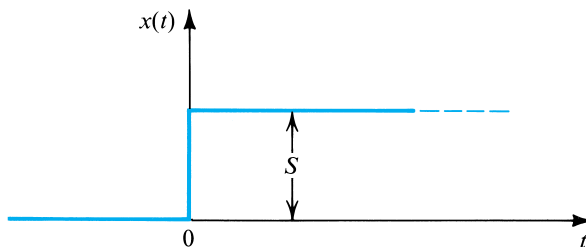

Figure E.9 A step-function signal of height S .

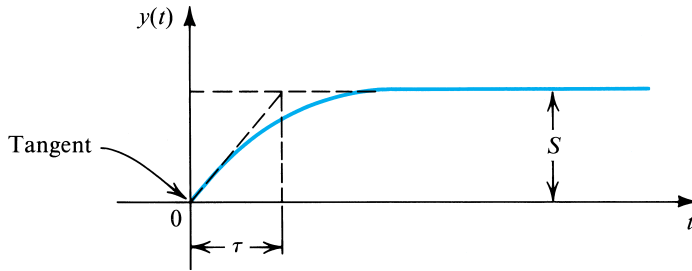

Figure E.10 The output $y(t)$ of a low-pass STC circuit excited by a step of height S .

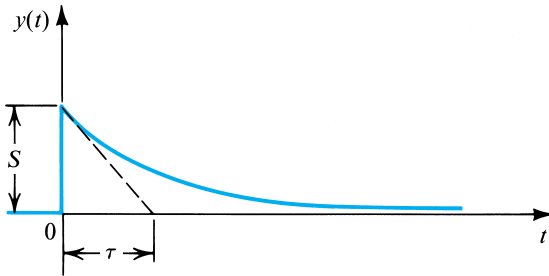

Figure E.11 The output $y(t)$ of a high-pass STC circuit excited by a step of height S .

any time t is equal to the difference between the final value Y_∞ and a gap that has an initial value of $Y_\infty - Y_{0+}$ and is “shrinking” exponentially. In our case, $Y_\infty = S$ and $Y_{0+} = 0$; thus,

$$y(t) = S(1 - e^{-t/\tau}) \quad (\text{E.10})$$

The reader’s attention is drawn to the slope of the tangent to $y(t)$ at $t = 0$, which is indicated in Fig. E.10.

E.4.2 High-Pass Circuits

The response of an STC high-pass circuit (with a high-frequency gain $K = 1$) to an input step of height S is shown in Fig. E.11. The high-pass circuit faithfully transmits the transient part of the input signal (the step change) but blocks the dc. Thus the output at $t = 0$ follows the input,

$$Y_{0+} = S$$

and then it decays toward zero,

$$Y_\infty = 0$$

Substituting for Y_{0+} and Y_∞ in Eq. (E.9) results in the output $y(t)$,

$$y(t) = Se^{-t/\tau} \quad (\text{E.11})$$

The reader’s attention is drawn to the slope of the tangent to $y(t)$ at $t = 0$, indicated in Fig. E.11.

Example E.5

This example is a continuation of the problem considered in Example E.3. For an input v_i that is a 10-V step, find the condition under which the output v_o is a perfect step.

Solution

Following the analysis in Example E.3, which is illustrated in Fig. E.3, we have

$$v_{o1} = k_r [10(1 - e^{-t/\tau})]$$

where

$$k_r \equiv \frac{R_2}{R_1 + R_2}$$

and

$$v_{o2} = k_c (10e^{-t/\tau})$$

where

$$k_c \equiv \frac{C_1}{C_1 + C_2}$$

and

$$\tau = (C_1 + C_2)(R_1 \parallel R_2)$$

Thus

$$\begin{aligned} v_o &= v_{o1} + v_{o2} \\ &= 10k_r + 10e^{-t/\tau}(k_c - k_r) \end{aligned}$$

It follows that the output can be made a perfect step of height $10k_r$ volts if we arrange that

$$k_c = k_r$$

that is, if the resistive voltage divider ratio is made equal to the capacitive voltage divider ratio.

This example illustrates an important technique, namely, that of the “compensated attenuator.” An application of this technique is found in the design of the oscilloscope probe. The oscilloscope probe problem is investigated in Problem E.3.

EXERCISES

E.7 For the circuit of Fig. E.4(f), find v_o if i_i is a 3-mA step, $R = 1 \text{ k}\Omega$, and $C = 100 \text{ pF}$.

Ans. $3(1 - e^{-10^7 t})$

E.8 In the circuit of Fig. E.5(f), find $v_o(t)$ if i_i is a 2-mA step, $R = 2 \text{ k}\Omega$, and $L = 10 \text{ }\mu\text{H}$.

Ans. $4e^{-2 \times 10^8 t}$

E.9 The amplifier circuit of Fig. EE.6 is fed with a signal source that delivers a 20-mV step. If the source resistance is $100 \text{ k}\Omega$, find the time constant τ and $v_o(t)$.

Ans. $\tau = 2 \times 10^{-2} \text{ s}$; $v_o(t) = 1 \times e^{-50t}$

E.10 For the circuit in Fig. E.2 with $C_1 = C_2 = 0.5 \text{ }\mu\text{F}$, $R = 1 \text{ M}\Omega$, find $v_o(t)$ if $v_i(t)$ is a 10-V step.

Ans. $5e^{-t}$

E.11 Show that the area under the exponential of Fig. E.11 is equal to that of the rectangle of height S and width τ .

E.5 Pulse Response of STC Circuits

Figure E.12 shows a pulse signal whose height is P and whose width is T . We wish to find the response of STC circuits to input signals of this form. Note at the outset that a pulse can be considered as the sum of two steps: a positive one of height P occurring at $t = 0$ and a negative one of height P occurring at $t = T$. Thus, the response of a linear circuit to the pulse signal can be obtained by summing the responses to the two step signals.

E.5.1 Low-Pass Circuits

Figure E.13(a) shows the response of a low-pass STC circuit (having unity dc gain) to an input pulse of the form shown in Fig. E.12. In this case, we have assumed that the time constant τ is in the same range as the pulse width T . As shown, the LP circuit does not respond immediately to the step change at the leading edge of the pulse; rather, the output starts to rise exponentially toward a final value of P . This exponential rise, however, will be stopped at time $t = T$, that is, at the trailing edge of the pulse when the input undergoes a negative step change. Again, the output will respond by starting an exponential decay toward the final value of the input, which is zero. Finally, note that the area under the output waveform will be equal to the area under the input pulse waveform, since the LP circuit faithfully passes dc.

A low-pass effect usually occurs when a pulse signal from one part of an electronic system is connected to another. The low-pass circuit in this case is formed by the output resistance (Thévenin's equivalent resistance) of the system part from which the signal originates and the input capacitance of the system part to which the signal is fed. This unavoidable low-pass filter will cause distortion—of the type shown in Fig. E.13(a)—of the pulse signal. In a well-designed system such distortion is kept to a low value by arranging that the time constant τ be much smaller than the pulse width T . In this case, the result will be a slight rounding of the pulse edges, as shown in Fig. E.13(b). Note, however, that the edges are still exponential.

The distortion of a pulse signal by a parasitic (i.e., unwanted) low-pass circuit is measured by its *rise time* and *fall time*. The rise time is conventionally defined as the time taken by the amplitude to increase from 10% to 90% of the final value. Similarly, the fall time is the time during which the pulse amplitude falls from 90% to 10% of the maximum value. These definitions are illustrated in Fig. E.13(b). By use of the exponential equations of the rising and falling edges of the output waveform, it can be easily shown that

$$t_r = t_f \simeq 2.2\tau \quad (\text{E.12})$$

which can be also expressed in terms of $f_0 = \omega_0/2\pi = 1/2\pi\tau$ as

$$t_r = t_f \simeq \frac{0.35}{f_0} \quad (\text{E.13})$$

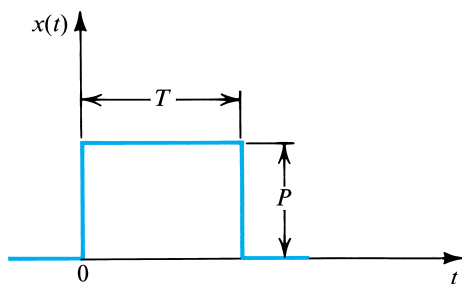

Figure E.12 A pulse signal with height P and width T .

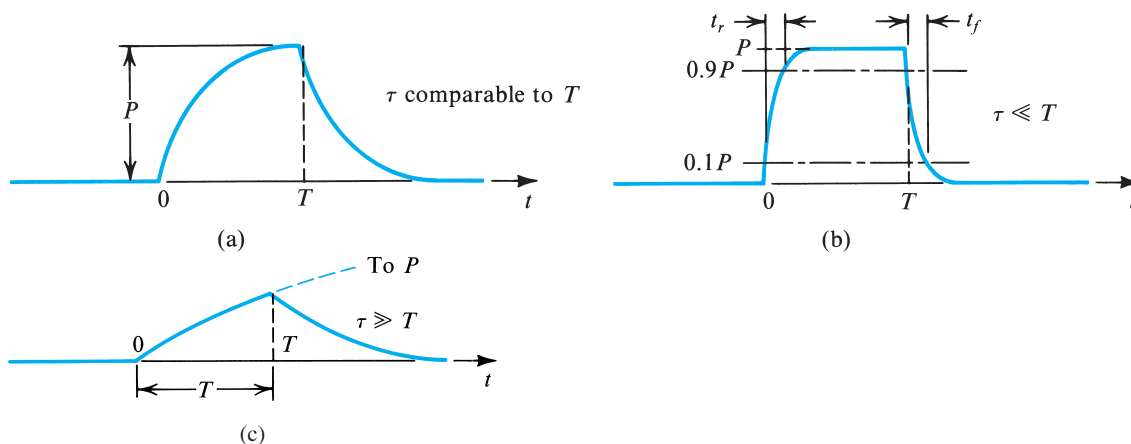

Figure E.13 Pulse responses of three STC low-pass circuits.

Finally, we note that the effect of the parasitic low-pass circuits that are always present in a system is to “slow down” the operation of the system: To keep the signal distortion within acceptable limits, one has to use a relatively long pulse width (for a given low-pass time constant).

The other extreme case—namely, when τ is much larger than T , is illustrated in Fig. E.13(c). As shown, the output waveform rises exponentially toward the level P . However, since $\tau \gg T$, the value reached at $t = T$ will be much smaller than P . At $t = T$, the output waveform starts its exponential decay toward zero. Note that in this case the output waveform bears little resemblance to the input pulse. Also note that because $\tau \gg T$, the portion of the exponential curve from $t = 0$ to $t = T$ is almost linear. Since the slope of this linear curve is proportional to the height of the input pulse, we see that the output waveform approximates the time integral of the input pulse. That is, a low-pass network with a large time constant approximates the operation of an *integrator*.

E.5.2 High-Pass Circuits

Figure E.14(a) shows the output of an STC HP circuit (with unity high-frequency gain) excited by the input pulse of Fig. E.12, assuming that τ and T are comparable in value. As shown, the step transition at the leading edge of the input pulse is faithfully reproduced at the output of the HP circuit. However, since the HP circuit blocks dc, the output waveform immediately starts an exponential decay toward zero. This decay process is stopped at $t = T$, when the negative step transition of the input occurs and the HP circuit faithfully reproduces it. Thus, at $t = T$ the output waveform exhibits an *undershoot*. Then it starts an exponential decay toward zero. Finally, note that the area of the output waveform above the zero axis will be equal to that below the axis for a total average area of zero, consistent with the fact that HP circuits block dc.

In many applications, an STC high-pass circuit is used to couple a pulse from one part of a system to another part. In such an application, it is necessary to keep the distortion in the pulse shape as small as possible. This can be accomplished by selecting the time constant τ to be much longer than the pulse width T . If this is indeed the case, the loss in amplitude during the pulse period T will be very small, as shown in Fig. E.14(b). Nevertheless, the output waveform still swings negatively, and the area under the negative portion will be equal to that under the positive portion.

Consider the waveform in Fig. E.14(b). Since τ is much larger than T , it follows that the portion of the exponential curve from $t = 0$ to $t = T$ will be almost linear and that its slope

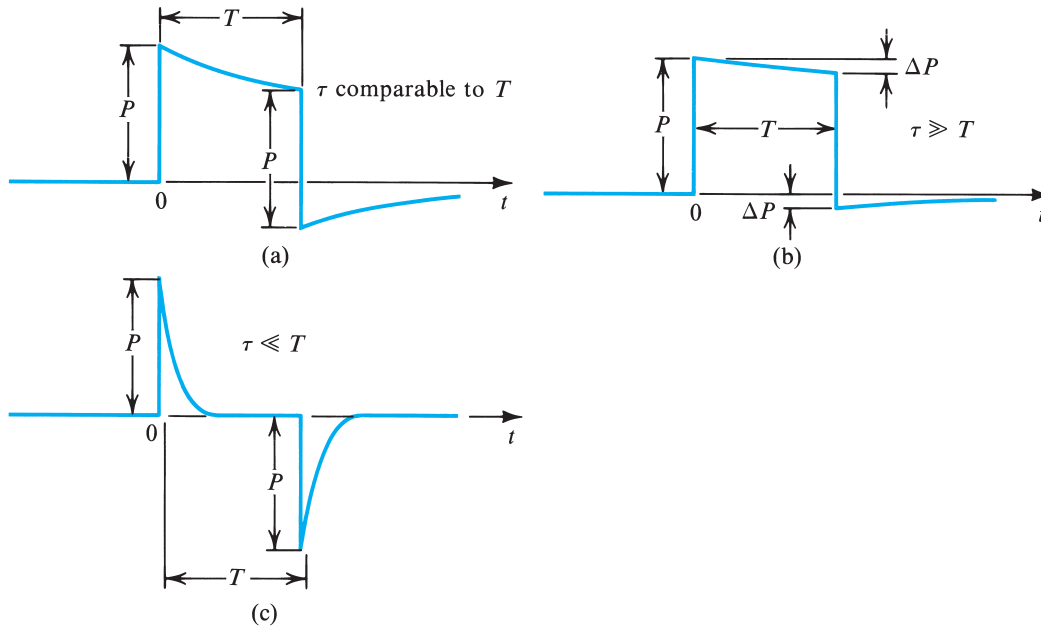

Figure E.14 Pulse responses of three STC high-pass circuits.

will be equal to the slope of the exponential curve at $t = 0$, which is P/τ . We can use this value of the slope to determine the loss in amplitude ΔP as

$$\Delta P \simeq \frac{P}{\tau} T \quad (\text{E.14})$$

The distortion effect of the high-pass circuit on the input pulse is usually specified in terms of the per-unit or percentage loss in pulse height. This quantity is taken as an indication of the “sag” in the output pulse,

$$\text{Percentage sag} \equiv \frac{\Delta P}{P} \times 100 \quad (\text{E.15})$$

Thus

$$\text{Percentage sag} = \frac{T}{\tau} \times 100 \quad (\text{E.16})$$

Finally, note that the magnitude of the undershoot at $t = T$ is equal to ΔP .

The other extreme case—namely, $\tau \ll T$ —is illustrated in Fig. E.14(c). In this case, the exponential decay is quite rapid, resulting in the output becoming almost zero shortly beyond the leading edge of the pulse. At the trailing edge of the pulse, the output swings negatively by an amount almost equal to the pulse height P . Then the waveform decays rapidly to zero. As seen from Fig. E.14(c), the output waveform bears no resemblance to the input pulse. It consists of two spikes: a positive one at the leading edge and a negative one at the trailing edge. Note that the output waveform is approximately equal to the time derivative of the input pulse. That is, for $\tau \ll T$, an STC high-pass circuit approximates a *differentiator*. However, the resulting differentiator is not an ideal one; an ideal differentiator would produce two impulses. Nevertheless, high-pass STC circuits with short time constants are employed in some applications to produce sharp pulses or spikes at the transitions of an input waveform.

EXERCISES

- E.12** Find the rise and fall times of a $1\text{-}\mu\text{s}$ pulse after it has passed through a low-pass RC circuit with a corner frequency of 10 MHz.
Ans. 35 ns
- E.13** Consider the pulse response of a low-pass STC circuit, as shown in Fig. E.13(c). If $\tau = 100T$, find the output voltage at $t = T$. Also, find the difference in the slope of the rising portion of the output waveform at $t = 0$ and $t = T$ (expressed as a percentage of the slope at $t = 0$).
Ans. $0.01P$; 1%
- E.14** The output of an amplifier stage is connected to the input of another stage via a capacitance C . If the first stage has an output resistance of $10\text{ k}\Omega$, and the second stage has an input resistance of $40\text{ k}\Omega$, find the minimum value of C such that a $10\text{-}\mu\text{s}$ pulse exhibits less than 1% sag.
Ans. $0.02\text{ }\mu\text{F}$
- E.15** A high-pass STC circuit with a time constant of $100\text{ }\mu\text{s}$ is excited by a pulse of 1-V height and $100\text{-}\mu\text{s}$ width. Calculate the value of the undershoot in the output waveform.
Ans. 0.632 V

PROBLEMS

E.1 Consider the circuit of Fig. E.3(a) and the equivalent shown in (d) and (e). There, the output, $v_o = v_{o1} + v_{o2}$, is the sum of outputs of a low-pass and a high-pass circuit, each with the time constant $\tau = (C_1 + C_2)(R_1 \parallel R_2)$. What is the condition that makes the contribution of the low-pass circuit at zero frequency equal to the contribution of the high-pass circuit at infinite frequency? Show that this condition can be expressed as $C_1 R_1 = C_2 R_2$. If this condition applies, sketch $|V_o/V_i|$ versus frequency for the case $R_1 = R_2$.

E.2 Use the voltage divider rule to find the transfer function $V_o(s)/V_i(s)$ of the circuit in Fig. E.3(a). Show that the transfer function can be made independent of frequency if the condition $C_1 R_1 = C_2 R_2$ applies. Under this condition the circuit is called a *compensated attenuator*. Find the transmission of the compensated attenuator in terms of R_1 and R_2 .

D **E.3 The circuit of Fig. E.3(a) is used as a compensated attenuator (see Problems E.1 and E.2) for an

oscilloscope probe. The objective is to reduce the signal voltage applied to the input amplifier of the oscilloscope, with the signal attenuation independent of frequency. The probe itself includes R_1 and C_1 , while R_2 and C_2 model the oscilloscope input circuit. For an oscilloscope having an input resistance of $1\text{ M}\Omega$ and an input capacitance of 30 pF , design a compensated “10-to-1 probe”—that is, a probe that attenuates the input signal by a factor of 10. Find the input impedance of the probe when connected to the oscilloscope, which is the impedance seen by v_i in Fig. E.3(a). Show that this impedance is 10 times higher than that of the oscilloscope itself. This is the great advantage of the 10:1 probe.

E.4 In the circuits of Figs. E.4 and E.5, let $L = 10\text{ mH}$, $C = 0.01\text{ }\mu\text{F}$, and $R = 1\text{ k}\Omega$. At what frequency does a phase angle of 45° occur?

***E.5** Consider a voltage amplifier with an open-circuit voltage gain $A_{vo} = -100\text{ V/V}$, $R_o = 0$, $R_i = 10\text{ k}\Omega$, and

an input capacitance C_i (in parallel with R_i) of 10 pF. The amplifier has a feedback capacitance (a capacitance connected between output and input) $C_f = 1$ pF. The amplifier is fed with a voltage source V_s having a resistance $R_s = 10$ k Ω . Find the amplifier transfer function $V_o(s)/V_s(s)$ and sketch its magnitude response versus frequency (dB vs. frequency) on a log axis.

E.6 For the circuit in Fig. PE.6, assume the voltage amplifier to be ideal. Derive the transfer function $V_o(s)/V_i(s)$. What type of STC response is this? For $C = 0.01$ μ F and $R = 100$ k Ω , find the corner frequency.

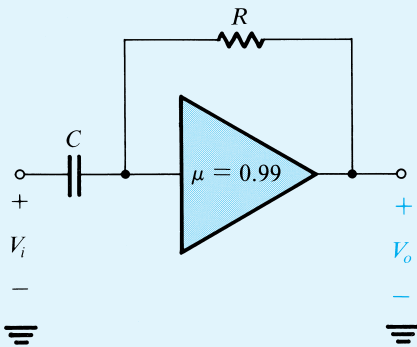

Figure PE.6

E.7 For the circuits of Figs. E.4(b) and E.5(b), find $v_o(t)$ if v_i is a 10-V step, $R = 1$ k Ω , and $L = 1$ mH.

E.8 Consider the exponential response of an STC low-pass circuit to a 10-V step input. In terms of the time constant τ , find the time taken for the output to reach 5 V, 9 V, 9.9 V, and 9.99 V.

E.9 The high-frequency response of an oscilloscope is specified to be like that of an STC LP circuit with a 100-MHz corner frequency. If this oscilloscope is used to display an ideal step waveform, what rise time (10% to 90%) would you expect to observe?

E.10 An oscilloscope whose step response is like that of a low-pass STC circuit has a rise time of t_s seconds. If an input signal having a rise time of t_w seconds is displayed, the waveform seen will have a rise time t_d seconds, which can be found using the empirical formula $t_d = \sqrt{t_s^2 + t_w^2}$. If $t_s = 35$ ns, what is the 3-dB frequency of the oscilloscope? What is

the observed rise time for a waveform rising in 100 ns, 35 ns, and 10 ns? What is the actual rise time of a waveform whose displayed rise time is 49.5 ns?

E.11 A pulse of 10-ms width and 10-V amplitude is transmitted through a system characterized as having an STC high-pass response with a corner frequency of 10 Hz. What undershoot would you expect?

E.12 An RC differentiator having a time constant τ is used to implement a short-pulse detector. When a long pulse with $T \gg \tau$ is fed to the circuit, the positive and negative peak outputs are of equal magnitude. At what pulse width does the negative output peak differ from the positive one by 10%?

E.13 A high-pass STC circuit with a time constant of 1 ms is excited by a pulse of 10-V height and 1-ms width. Calculate the value of the undershoot in the output waveform. If an undershoot of 1 V or less is required, what is the time constant necessary?

E.14 A capacitor C is used to couple the output of an amplifier stage to the input of the next stage. If the first stage has an output resistance of 2 k Ω and the second stage has an input resistance of 3 k Ω , find the value of C so that a 1-ms pulse exhibits less than 1% sag. What is the associated 3-dB frequency?

D E.15 An RC differentiator is used to convert a step voltage change V to a single pulse for a digital-logic application. The logic circuit that the differentiator drives distinguishes signals above $V/2$ as “high” and below $V/2$ as “low.” What must the time constant of the circuit be to convert a step input into a pulse that will be interpreted as “high” for 10 μ s?

D E.16 Consider the circuit in Fig. E.7(a) with $\mu = -100$, $C_f = 100$ pF, and the amplifier being ideal. Find the value of R so that the gain $|V_o/V_s|$ has a 3-dB frequency of 1 kHz.